



Magpie
Computer Developments
Ltd

www.magpiecd.com

Digital Sound System for Battery Locomotives

Installation Manual

Features:

- 5 Sound Sequences from 4 Switch Inputs:
 - Engine Start-up Sequence
 - Engine Shut-down Sequence
 - Low Horn (Continuous)
 - High Horn (Continuous)
 - Two Tone Horn
- Same Sound Quality as its bigger Brother
- Universal 12V Operation
- Engine Sound synchronised to Loco Speed
- Straightforward Installation
- 40W Amplifier and Speaker Included
- Opto-isolated Locomotive Speed-sensing system.
- Suitable for use in any Battery-powered locomotive
- Uses existing Control handset
- Pre-programmed with Loco sounds to order.

Digital Sound Samples provided by, and copyright of,
South West Digital Ltd

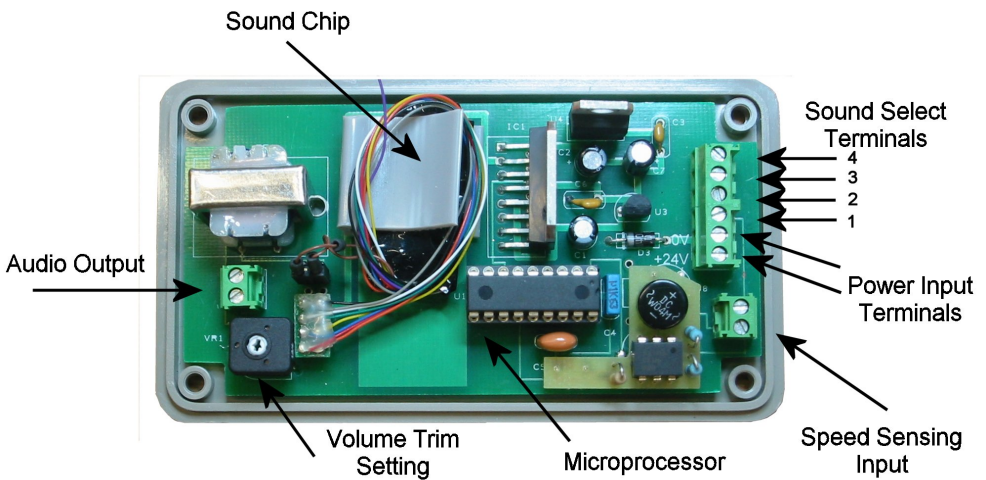

There are 10 Connections to be made to the Sound Unit, arranged into 4 functional 'groups'.

The **Audio Output** terminals on the left side are used to connect the sound to the Power Amplifier. For best sound quality, audio co-axial cable should be used.

On the right side of the unit, from bottom-to-top, there are:

Speed-Sensing input. These two terminals are connected to the motor-drive outputs of your Locomotive Controller. Polarity is unimportant.

Power Input terminals. These two terminals are used to supply power to the Unit. The Lower terminal is connected to +12V, and the Upper to 0V. The unit is protected against accidental reverse-connection.

Sound Select Terminals. These 4 terminals control the sounds. .

The sounds are activated by connecting the appropriate terminal to 0V using a suitable switch, relay or Open Collector drive on your handset / Control System. This action is referred to as 'Switching ON'. Three of the sounds will play for as long as the Input is switched ON. To end the sound, disconnect the terminal from 0V (Switch OFF).

IMPORTANT NOTE: On NO account should any voltage be applied to these terminals. Doing so may cause irreparable damage to the Sound Unit's microprocessor!

Sounds in detail.

Sound Select 4, when switched ON, will play a two-tone Horn Sound ONCE only. The input must be switched OFF before it will play again.

Sound Select 3 will play a High Horn Sound for as long as the Input is ON.

Sound Select 2 is the Low Horn Sound. This also will play for as long as the Input is ON.

Sound Select 1 has 4 functions. Its primary function is to turn engine Sound On and Off. When the Engine is Off, and the Locomotive is stationary, switching this Input ON will begin the Engine Start-up Sequence, after which the engine will Idle. When the engine is Idling, and the loco is stationary, switching this input OFF will begin the engine Shut-Down sequence after about 2 seconds.

Alternate Function 1 – **Volume Mute.**

To mute the sound temporarily, proceed as follows: With the Locomotive stationary, and the engine Idling, switch Input 1 Off, then back On within 2 seconds. The sound volume will be muted. Switching Input 1 Off and On again will restore the Volume to its original level, and resume normal operation.

Alternate Function 2 – **Volume Adjust.**

Proceed as above. When the sound is Muted, switch any of Inputs 2, 3 or 4 On. The sound will begin to increase. When it reaches the desired level, switch that Input Off. The unit will resume normal operation.

Alternate Function 3 – **Forced Idle.** Switch Input 1 , then back On within 2 seconds, whilst the loco is under power, and the engine sound will be forced into idle. This feature is useful when you want to simulate 'coasting' to a stand whilst maintaining power for loco movement, eg when arriving at a station, or slowing for a signal check. Forced idle will be cancelled automatically when the loco stops, or if you accelerate away without stopping.

Optionally, Input 1 can be permanently connected to 0V. If this is done, the engine Start-up sequence will play as soon as power is applied to the Sound Unit. If this option is chosen, neither Engine Shut-down nor any of the Alternate Functions can be used.

Driving the Loco with sounds.

Moving the handset speed-control a little will generate a 'brakes-off' sound, followed by Power take-up. At this point, you should move the speed control further to start loco movement, and the engine sounds will increase in revs in synchronisation with speed. You will soon get the 'feel' of how to advance the speed control to provide perfect synchronisation between Loco Movement and engine sound.

Decrease the speed, and the engine revs will reduce, returning to idle when the loco stops.

A word about the Volume Trim Setting

The Volume Trim Setting is used to 'trim' the audio circuit to give maximum volume with minimum distortion.

1. Set the Amplifier Volume to Maximum
2. Set the unit to maximum volume using Alternate Function 2 (page 3)
3. Adjust the Volume Trim Setting to achieve the 'best quality' of sound
4. Set the 'operational' volume as required from time-to-time using Alternate Function 2 (page 3). *Do not disturb the Volume Trim Setting discovered in step 3.*

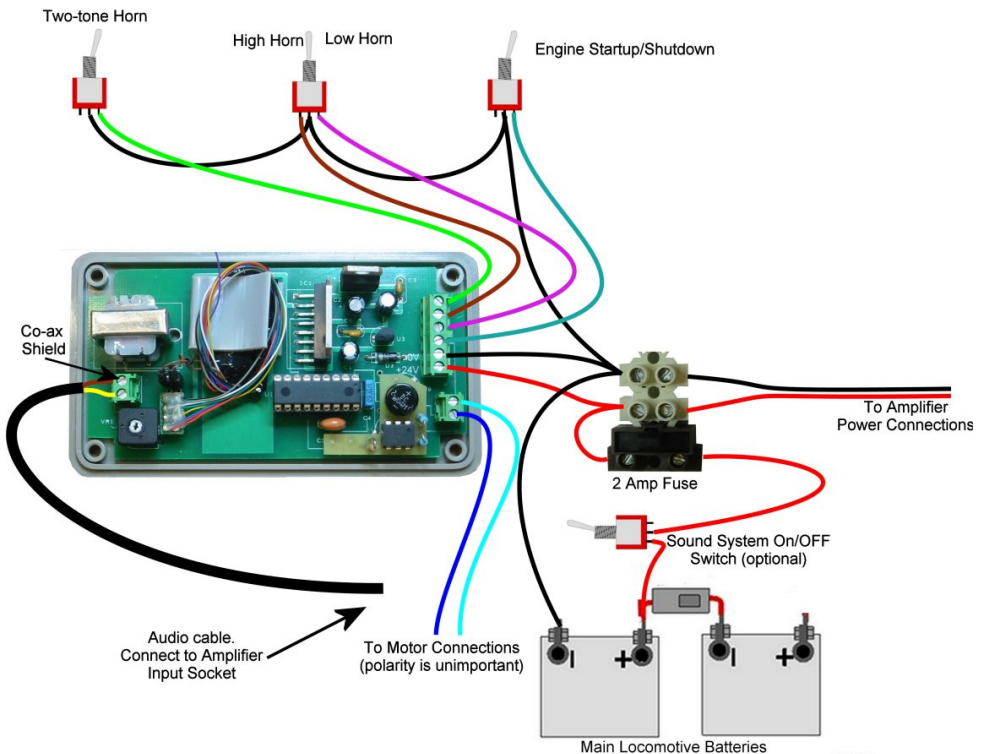

Document Revision

20th Sep 2010	Change Wiring for New Amplifier Arrangement
15th Sep 2009	Rev A . Clarify Volume Trim Setting
3rd April 2008	Initial Release